

EVALUATION OF THE USE OF A MICROCONTROLLER OF PLATFORM ARDUINO IN ELECTRICAL SENSOR READING FOR CORRELATION WITH SOIL PROPERTIES

Victor George Celinski¹, Fábio Vinicius de F. Damiani¹, Lucas F. de Camargo¹

¹ Universidade Estadual de Ponta Grossa (UEPG) – Ponta Grossa, PR – Brasil
vgcelinski@uepg.br, viniciusdamiati@gmail.com, lucasfercam@outlook.com

Abstract. *This paper presents the values obtained with electrical resistance sensors, and collected through an Arduino microcontroller. These data were compared with the results obtained in the laboratory and had a correlation coefficient of 92%. The data obtained from the sensors, collected and stored by a microcontroller can assist in precision agriculture, due to greater accessibility to them. Additionally, the proposed system presents itself as a new way to automate the data collection of soil and to work with these data.*

Keywords. *Arduino, soil attributes, electrical resistance sensor.*

1. Introduction

Brazil is a country where the agricultural sector has strength and relevance as the large territorial extension and variety of climate provide the activity is done on a large scale. With this, Brazil is also one of the largest exporters of the world's food, where exports tons of food to more than 180 countries, with the major buyers China, European Union and United States, in addition to the Mercosur countries. One of the major problems of agriculture is the inputs that are applied in the soil to increase production, which in addition to damaging the environment and health, are expensive and often misused as its dosage Mapa [7].

Since the dawn of the twentieth century, some researchers try to develop a methodology for the producers to sample, test and map the soils in a simple and practical way. In the search for better financial returns and production increase, with the decrease amount of application of inputs, less degradation of the soil and the environment, farmers have precision agriculture as a more effective method of production Guerra [4].

With precision agriculture, there is the desired increase in productivity, but with benefits for the farmer, as the reduction of spending on products used in incorrect quantity and agility and process automation; and for the end consumer, in the food supply with fewer inputs Celinski [1].

Thus, precision farming techniques should improve the economic and environmental sustainability of production. This is due to the fact the set of techniques and procedures used in the technique allows to know, geolocate and delineate areas of different productivity through the use of computing technology, specific programs, sensors, machine controllers and global positioning system (GPS) Pincinelli [8].

One of the main factors analyzed in this process is the soil. Some fields may be uniform, but others have variations in soil type, fertility and other factors affecting agricultural production. The variability of the field can be measured and recorded, this information may be used to optimize the applications at each point. In addition, the detailed mapping of factors of production and localized application of inputs are essential points of precision agriculture Guerra [4]. As Marcelino [6], soil analysis

needs a lot of samples to study its physical and chemical properties, then taken to the laboratory and analyzed. To Grego et al. [3], to investigate the possible causes of difference between productivity of cultures in the same space has been attributed to soil factors as the cause, including the physical and chemical properties. However, these properties are obtained by sampling, usually requiring high demand for hand labor, time and cost. The electrical properties of the soil have been calling attention mainly because they are obtained quickly, efficiently and with low cost, using direct contact with the ground sensors.

The sensors are designed to decrease time analysis of soil samples. The sensors work with tools of analog and digital measurements, to obtain the potential difference, resistivity, conductance and soil electrical capacitance. Most sensors provide an output signal which is affected by more than one agronomic characteristic of the soil. Electrical and electromagnetic sensors are measuring instruments based on electrical circuits and used to determine the ability of certain means to drive or accumulate electric charge. If the soil is used as such a medium, its physical and chemical properties can affect the behavior of the circuit, thus the measured electrical parameters.

According to Pincelli [8], are used as techniques of precision agriculture the correlations found between the concepts of electrical conductivity with soil properties (texture, moisture, salinity, acidity), as may be seen in research papers, Rocha et al. [9] checked in their research the potential of the use of a portable meter of soil electrical conductivity as an auxiliary tool in the characterization of soils. Leite et al. [5] tested the effect of correctives in the soil properties and concluded that application of gypsum reduced the electrical conductivity and soil sodium concentration. Souza et al. [12] evaluated the increased application of fertilizer rates, acidified soil solution and increased electrical conductivity. Sana et al. [10] studied the relations between soil properties which interfere in cotton yield and found that the electrical conductivity of the soil was a suitable tool for the identification of the variability of acidity and of nutrients in the soil under the condition studied allowing delimiting homogeneous areas, for management of differently culture. Silva et al. [11] investigated the spatial distribution of electrical conductivity of the saturation extract, total organic carbon and organic matter in a Fluvisol soil and obtained electrical conductivity maps inversely proportional to the organic matter and organic carbon, but found that the maps of isolines presented homogeneity and similarity.

This study aimed to assess the implementation of the Arduino microcontroller as a new methodology to automate the collection of data of soil properties in precision agriculture by comparing the values of readings of electrical resistivity sensor obtained by the microcontroller with the values obtained by analysis in laboratory of soil attributes.

2. Materials and Methods

The collection of soil samples was conducted in a no-tillage area in Capão da Onça Farm, belonging to Ponta Grossa State University with approximately 6 hectares, totaling 30 samples. This set of samples was sent to the Laboratory of Soil of the Faculty of Agricultural Sciences of the Paulista State University of Botucatu where the chemical analyses of the soil were carried out. The experiment was conducted in the Electronics Laboratory of the Department of Informatics of State University of Ponta Grossa. To perform electrical resistance measurements of soil samples, it was used an Arduino microcontroller UNO ATmega 328, the choice of this model was because of

the following factors: has 14 digital pins of input/output, 6 analog inputs, it is a hardware of electronics projects development based on open hardware concept, this concept has similar meaning to free software, where the entire development project is made available to the community, can be programmed with the Arduino IDE, available on the platform's website, the language is based on languages C/C++ programming, it has low cost, there is a lot of information on libraries available as open source and available on the Internet, as tutorials and video lessons.

For Arduino works with the ohmmeter, it was calculated a voltage divider in the input of the analog signal of the microcontroller, in which one of the resistors had a fixed value and the other was the electrical resistance of the sensor Octopus Soil Humidity, modified to meet the proposed methodology for the development of this work, as can be seen in figure 1. In its standard form, this sensor uses the two probes for passing current through the soil and then reads the ground voltage to obtain the humidity level; the sensor is simple, inexpensive and a resistive type. In order for this sensor to be used for reading the electrical resistance of the soil, an adjustment was necessary in the same electrical circuit. The two rods were connected directly to the sensor output, where each side of the sensor (front and back) represents a polarity of the electric circuit system (positive and negative). To calibrate the microcontroller functioning as ohmmeter was used the 30 soil samples, measured with the microntrolador and also measured with the analog multimeter operating as ohmmeter, using the same sensor. Measurements of samples in each case were measured with duration of 5 minutes to stabilize readings.

Before each measurement, the samples were measured for the same standard of humidity sensor using another Octopus Soil Humidity connected to Arduino without modification, according to Figure 1.

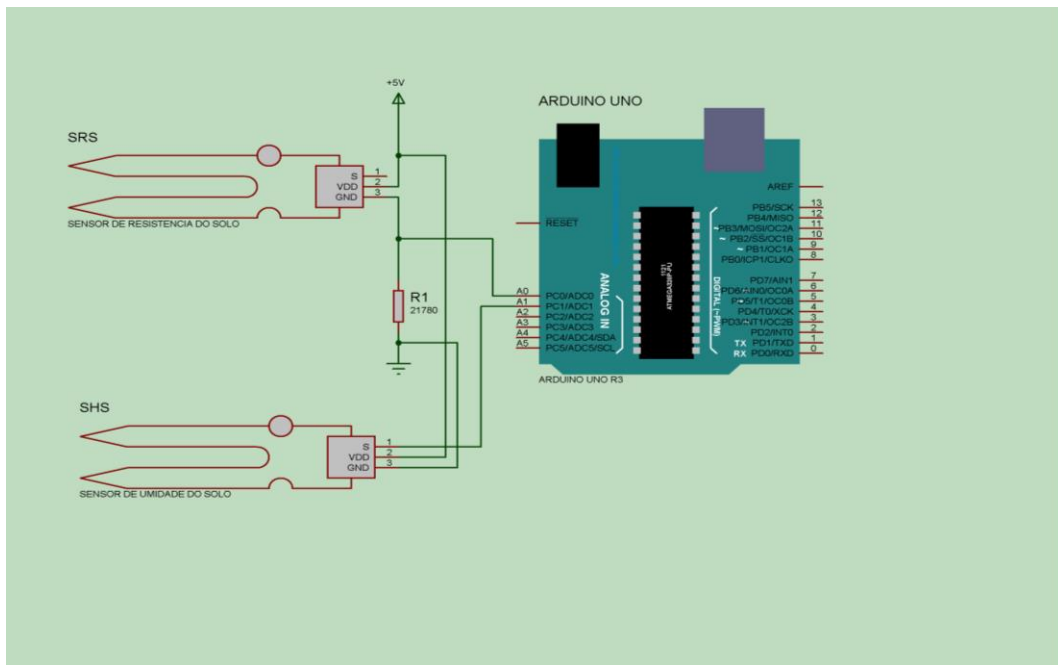

Figure 1 - Electric circuit design

From these measurements, were tested some correlation equations to be used in the Arduino software in order to obtain the values of soil attributes directly on Arduino microcontroller. To analyze the distribution of points in the charts we used the

methodology as Doria Filho [2], who classifies the linear correlation coefficients between variables as perfect, when the correlation coefficient is ($= 1$), strong (> 0.75), medium (> 0.5), weak (< 0.5) and absent ($=0$).

3. Results and Discussion

For the measured values of electrical resistance of the soil samples using the Arduino microcontroller compared with the measured values with the analog meter gave a correlation coefficient of 92% and a 85% determination index. The soil properties that have obtained better results correlated with the electrical resistance of the ground measured with the Arduino microcontroller were pH = 84%, CTC = 80% and V% = 79%, so these data were used for the experiment sequence.

To obtain the values of soil properties using the Arduino microcontroller were performed some calculations, whose formulas were obtained working with Excel, creating scatter plots for each soil attribute, tracing the lines of polynomial trend of the third order, obtaining the determination index and the correlation equations of each soil attribute, to be programmed into the arduino software in order to obtain the values of soil attributes directly on the arduino microcontroller. The equations are as follows, where: y is the value of the soil attribute obtained with the Arduino, E is the exponential value, x is the electric resistance value obtained with the Arduino and R^2 is the coefficient of determination.

For the calculation of pH, we used the equation 1, yielding a correlation of 0.84 and a coefficient of determination of 0.7124.

$$y = -2E-13x^3 - 1E-08x^2 + 0.0005x + 1.2266 \quad (1)$$

The scatter plot between the electrical resistance of the soil measured with Arduino microcontroller and the value of soil attribute pH analyzed in laboratory generated the polynomial trend of third order, the correlation equation and the determination index that can be viewed in graph 1.

Graph 1: Dispersion between the electrical resistance of the soil and pH

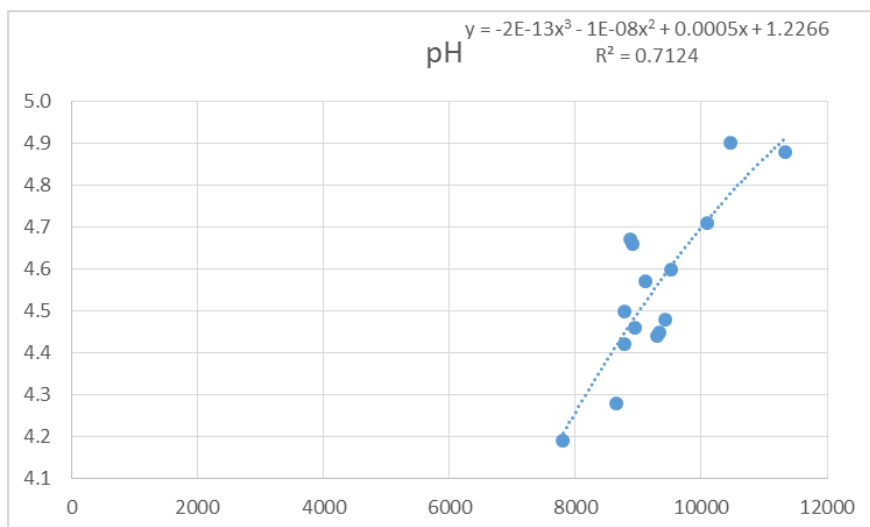

In Graph 1, calculated the correlation coefficient between the chart variables it was obtained a 0.84 index, indicating a strong correlation between the variables.

For the CTC calculation was used equation 2, resulting in a correlation coefficient of 0.80 and a coefficient of determination of 0.6371.

$$y = -1E-10x^3 + 4E-06x^2 - 0.0484x + 269.46 \quad (2)$$

The scatter plot between the electrical resistance of the soil measured with Arduino microcontroller and the value of soil attribute CTC analyzed in the laboratory generated the polynomial trend of third order, the correlation equation and the determination index that can be viewed in graph 2.

Graph 2 : Dispersion between soil electrical resistance and CTC

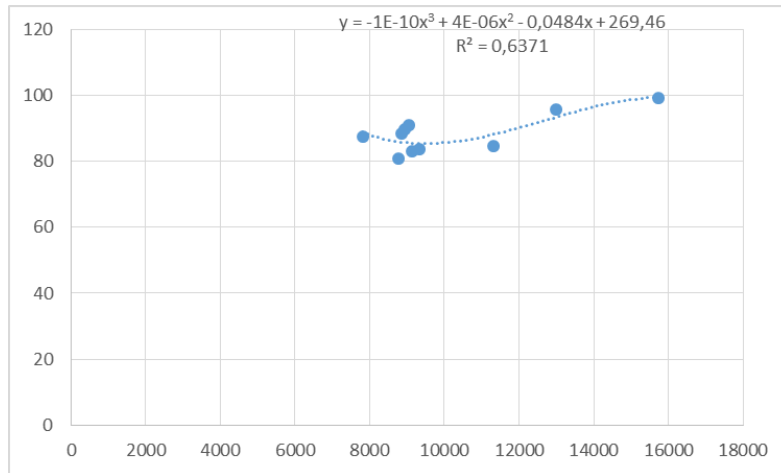

In Graph 2, calculated the correlation coefficient between the chart variables it was obtained a 0.80 index, indicating a strong correlation between the variables.

For calculation relative to the V%, it was used the equation 3. As a result, it was obtained 0.79 correlation index and 0.621 coefficient of determination.

$$y = 7E-10x^3 - 2E-05x^2 + 0.2219x - 765.49 \quad (3)$$

The scatter plot between the electrical resistance of the soil measured with Arduino microcontroller and the value of the soil attribute V% analyzed in the laboratory led to the polynomial trend of third order, the correlation equation and the determination index that can be viewed in graph 3.

Graph 3: Dispersion between soil electrical resistance and V% V%

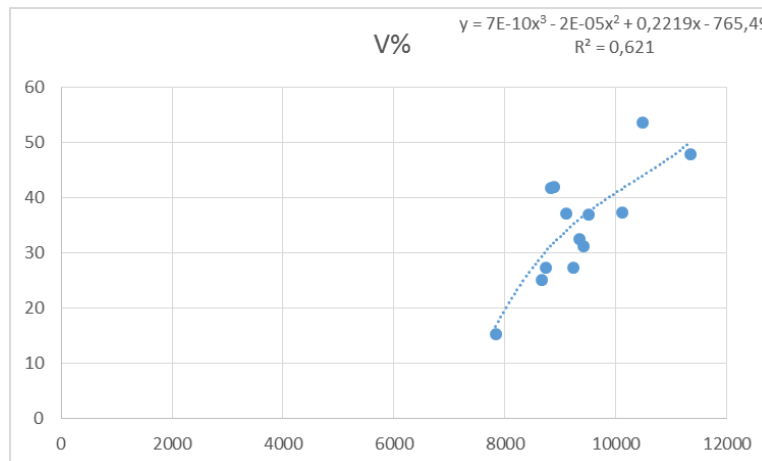

In Graph 3, calculated the correlation coefficient between the chart variables, it was obtained a 0.79 index, indicating a strong correlation between the variables.

The equations mentioned above were programmed into the Arduino software in order to obtain the measured values of soil samples attributes, as pH, CTC and V% directly into the Arduino microcontroller, the values were measured in soil samples previously used and compared with values obtained in the laboratory, resulting in a correlation value Ph = 43%, V% = 48% and CTC = 60%. According to the purpose of this research and the measured values, the sensor works adequately for measuring the electrical resistance of the soil, but has an average correlation for obtain the CTC values and the results of the experiment also demonstrated that the sensor showed a weak correlation to be used to obtain pH values and V% when measured directly with Arduino microcontroller.

4. Conclusion

The Arduino microcontroller is able to obtain electrical resistance measurements with practicality and accuracy, its use helps in the automation process of tasks, making the process agile for bringing answers almost immediate, and furthermore it concentrate the measures in a single device, making it simply, in addition to a low cost.

The results demonstrated that it is possible to obtain the values of soil attributes using the embedded software of Arduino with the sensor Octopus Soil Humidity modified to measure electrical resistance of the soil, correlating strongly with the attributes of the soil pH, CTC and V% and showing the possibility of being a useful tool to work for the localized management and soil fertility control aiming application of precision agriculture.

References

- [1] V. G. CELINSKI (2011). Capacitância elétrica e sua correlação com atributo do solo visando aplicação na agricultura de precisão, Anais do II Simpósio de Geoestatística em Ciências Agrárias, Botucatu. SP.
- [2] U. DORIA FILHO (1999). Introdução a bioestatística: para simples mortais. São Paulo: Negócio, 152 p.
- [3] C. R. GREGO; S. R. VIEIRA; J. P. MOLIN; F. R. M. MIGUEL; F. A. PAVLU (2006). Variabilidade espacial da condutividade elétrica do solo e da produtividade da mamona (*Ricinus communis* L.) no sistema de plantio direto. In: 2º. Congresso Brasileiro de Agricultura de Precisão. Anais... São Pedro, SP.
- [4] S. P. S. GUERRA (2006). Desenvolvimento de um sistema informatizado de menor custo para aquisição e armazenamento de dados de sensores analógicos e receptor GPS. 2006. 118 f. Tese (Doutorado em Agronomia, Energia na Agricultura) – Faculdade de Ciências Agrônômicas, Universidade Estadual Paulista, Botucatu.
- [5] M. J. H. LEITE; R. V. SANTOS; A. D. V. GOMES; A. F. M. VITAL (2012). O gesso agrícola reduziu o pH, condutividade elétrica e concentração de sódio do solo. Revista Verde, Mossoró, v.7, n.1, p. 87-95.

- [6] L. R. MARCELINO (2009). Condutividade elétrica do solo, tópicos e equipamentos, Embrapa Agropecuária, São Carlos, SP.
- [7] MAPA (2014). Ações da CAPTA voltadas ao fomento da Agricultura de Precisão. Available in: <<http://www.agricultura.gov.br/desenvolvimento-sustentavel/tecnologia-agropecuaria/agricultura-de-precisao>>. Access: May 2014.
- [8] A. L. S. PINCELLI (2004). Desenvolvimento e ensaios de um sistema de mensuração de condutividade elétrica do solo. 2004. 96 f. Dissertação (Mestrado em Agronomia)–Escola Superior de Agricultura Luiz de Queiroz, Universidade de São Paulo, Piracicaba.
- [9] M. G. ROCHA; P. S. NASCIMENTO; B. R. S. COSTA; J. A. SILVA; L. H. BASSOI; L. M. RABELLO (2011). Mapeamento da condutividade elétrica aparente do solo com sensor portátil em um argissolo no semiárido. In: XXXIII CONGRESSO BRASILEIRO DE CIÊNCIA DO SOLO. Anais... Center Convention, Uberlândia, MG.
- [10] R. S. SANA; I. ANGHINONI; Z. N. BRANDÃO; M. J. HOLZSCHUH (2014). Variabilidade espacial de atributos físico-químicos do solo e seus efeitos na produtividade do algodoeiro. *Revista Brasileira de Engenharia Agrícola e Ambiental*, Campina Grande, v.18, n.10, p.994–1002.
- [11] J. S. SILVA; A. A. A. MONTENEGRO; E. F. F. SILVA; C. W. L. ANDRADE; J. R. L. SILVA (2013). Distribuição Espacial da Condutividade Elétrica e Matéria Orgânica em Neossolo Flúvico. *Revista Brasileira de Geografia Física*, v.6, n.4, p. 764-776.
- [12] T. R. SOUZA; R. L. V. BOAS; J. A. QUAGGIO; L. C. SALOMÃO; L. C. FORATTO (2012). Dinâmica de nutrientes na solução do solo em pomar fertirrigado de citros. *Pesquisa Agropecuaria Brasileira*, Brasília, v.47, n.6, p.846-854, jun.